



Pallet racking use and maintenance guide

Operation, use, review and maintenance of conventional pallet racking facilities



CONTENTS:

	Pág.
0. Introduction.....	3
1. Scope.....	4
2. Normative references.....	4
3. Terms and definitions.....	5
4. Elements.....	8
5. Storage system configuration.....	12
6. Assembly.....	18
7. Advise on utilisation.....	22
8. Inspections and maintenance.....	23
ANNEX A. Supplier responsibility.....	31
ANNEX B. Load signal example.....	32

0.INTRODUCTION:

This guide, based on **EN 15635** Steel static storage systems, application and maintenance of storage equipment, gives guidelines for operational aspects relevant to structural safety of storage systems. Such systems operate with heavy mechanical handling equipment working in close proximity to static storage equipment. This minimizes the risk and consequences of unsafe operation or damage to the structure.

This manual will fit stores where units of load, usually palletized or in containers, are handled by forklift trucks or other equipment maintenance, so we will remove risks from manual loading in stores.

The use of a conventional shelving installation should be done under some minimum attention requirements in order to avoid accidents that can cause:

- High cost service interruptions.
- Insecure working conditions.
- Damaged products, useless shelves or even environmental problems.

A rational and secure use of the installation is achieved with close collaboration between shelving manufacturers, machine manufacturers, shelving owners and employees. All instructions and recommendations from manufacturers should be strictly followed. It is also strongly recommended to follow any type of planned activity that considers:

- **Prevention** damaged parts on the shelving.
- Frequent **inspection** of shelving conditions.
- Employee **training**.

All information required to prepare planned activities is exposed and explained on further pages. They all comply with **UNE-EN 15635** as regards manually loaded installations, being completely prohibited the loading or unloading with any mechanical aid.

VERY IMPORTANT! Surveillance, use and installation conditions are customers responsibilities. Customers should advise and train effectively all future workers of the warehouse.

All images shown can just be considered as examples and can never be used as a matter of future complaints.

1.SCOPE

KIMER ESTANTERÍAS has produced this manual in order to:

- Advise clients to provide each of the installations of conventional shelves for palletized load (APR), the safety and quality of the work necessary for the use of the same.
- Lay the foundation so that the user can make their prevention plans and the assessment of the conditions present in your installation of conventional shelves for palletized load.

This document must be applied in conjunction with the Standards EN 15512, EN 15620, EN 15629, EN 15635, EN 15878 y UNE 58013.

This manual applies to all equipment storage, manufactured in steel, which are active or in use, and in any area of storage (distribution centers, industrial, commercial, etc.)

This manual excludes storage equipment manufactured from materials other than Steel (except for certain accessories) and equipment intended to be used for domestic storage purposes.

2.STANDARDS FOR CONSULTATION

The standards listed below are indispensable for the application of this document.

- EN 15512, Adjustable pallet racking systems. Principles for structural design.
- EN 15620, Adjustable pallet racking. Tolerances, deformations and clearances.
- EN 15629, Specification of storage equipment.
- EN 15635, Application and maintenance of storage equipment.
- EN 15878, Terms and definitions.
- UNE 58013, Steel static storage systems. Requirements for treatment of damaged components.

3. TERMS AND DEFINITIONS:

3.1 APR (adjustable pallet racking); Steelwork structure consisting of frames and beams adjustable in height, specifically designed to support pallets and unit loads.

3.2 Bay load: Total allowable weight of all the unit loads in a bay of racking not including any unit loads that may be stored on the floor of the bay.

3.3 Compartment load: Load which can be loaded into one compartment of a racking or shelving structure from one side

3.4 Counterbalanced forklift truck: Ride-operated type of forklift truck that carries its load cantilevered forward of its front main wheel axle and is stabilized with a counter weight at the rear of the truck.

NOTE: This type of truck is a general-purpose truck and may be used in wide-aisle pallet racking systems

3.5 Design clearances: Nominal dimension items used in the design.

NOTE: These clearances enable input and output of the load to take place without contact of the load with any other loads or part of the storage system structure other than normal contact when the load is placed on the beams or other members provided for its support in storage.

3.6 Double deep racking: Racking in which pallets can be stored two deep from one aisle into the installation and accessed by a specially adapted long reach fork mechanism.

3.7 Drive in racking: System of racking that provides blocks of storage where pallets are stored two or more deep and Access is gained by driving a lift truck into a lane with pallets supported along their sides on beam rails supported from the uprights.

3.8 Drive through racking: System of racking that provides blocks of storage where pallets are stored two or more deep similar to DIR except that the truck can be driven into a lane on one side of the block and out of the other if there are no obstructions.

3.9 Frame load: Total allowable weight of all the unit loads transmitted to the frame by the members attached to the frame

3.10 Hand pallet truck: Small hand-operated truck used for moving pallets around on level floors and the pallet is lifted clear of the floor by raising and lowering a tiller bar operates a hydraulic lifting device..

3.11 Intrusive stacking: Placement or retrieval of a pallet where the turning radius or length of a lift truck is greater than the aisle width and part of the pallet storage concerned is used by the truck forks and load when turning to place or retrieve a pallet.

3.12 Mechanical handling equipment MHE: Mechanical equipment used to transport the unit load to be stored.

3.13 Mezzanine floors RSA: Additional floor above the ground floor slab level used for storage which can be free standing or attached to the building structure.

3.14 Narrow aisle racking: Pallet racking arranged in a similar way to wide aisle racking but having aisles of a reduced width for use with more specialist types of lift trucks.

3.15 Pallet: Portable platform, with or without superstructure, for the assembly of a quantity of goods to form a unit load for handling and storage by mechanical appliances.

3.16 Pallet buffer back stop: Buffering back stop, which is specified as an aid for use by forklift truck drivers to deposit a unit load in the correct position in the racking.

3.17 Pallet safety back stop: Safety back stop to prevent accidental collision of a pallet or its load with other unit loads or equipment, when that load is placed in the storage compartment.

Type a) safety device, which protects against unintentional load movement within the racking and prevents loads from protruding or from falling into an aisle or into an area accessible to people.

Type b) backstop to prevent accidental damage, usually placed at the back of a storage compartment, to prevent the accidental collision of a pallet or its load with other equipment, such as sprinklers, when a load is placed in the storage compartment.

3.18 Pick up and deposit stations, P and D stations: Storage locations at the end of an aisle used as an interface between different types of mechanical handling equipment.

NOTE: The P and D stations can be used as an interface between the unit load and handling equipment that is dedicated to the rack aisle (such as very narrow aisle (VNA) trucks or cranes) and the conveyors or free movements trucks which service the installation. The P and D stations can also be used to accurately fix the location of the unit load relative to the racking. This is often used by trucks or cranes having a fixed length of fork stroke and ensures accuracy in the X and Z directions when placing the unit load onto the racking beams.

3.19 Powered hand pallet truck: Small hand-operated truck used for moving pallets around on levels floors where the power for lifting and moving the pallet loads is provided by a battery and electric motor.

3.20 Reach truck: Stacking lift truck with outriggers where the load can be repositioned by moving the mast or fork arm carriage

NOTE: These trucks are generally used in narrow aisle racking because their overall length is less than a counterbalanced lift truck of the same lifting capacity

3.21 Shelving: Persona o empresa que proporciona al proveedor las especificaciones basadas en los requisitos del usuario.

3.22 Specified allowable unit load: Unit load allowed in the storage equipment.

3.23 Specifier: person or company that provides the supplier with a specification based on the user's requirements.

NOTE: The specifier can be a consultant or other specialist, the end or the equipment supplier acting as the specifier.

3.24 Storage equipment: Structure used to store the unit loads.

3.25 Straddle-type stacker trucks: Manually or electrically operated pallet trucks with straddle legs.

3.26 Supplier: Company that supplies the storage equipment

NOTE: The company may be the original manufacturer or an intermediate company acting as a distributor.

3.27 Total racking or shelving load : Total allowable load supported by all the primary load supporting

NOTE: This may be the total load from beams or shelves in a defined area of racking or shelving.

3.28 Unit load: Weight of an individual stored item that can be placed or retrieved in the operation.

3.29 User: Company or person who manages and operates the installation on a daily basis and is responsible for the continuing safety of the installation

3.30 Very narrow aisle racking VNA racking: Pallet racking arranged with aisles of a width to cater only for the truck and the unit load width plus an operational clearance where the truck cannot make 90° turns into the rack face for loading and off loading.

3.31 Very narrow aisle truck VNA truck: Rider operated fork lift truck which can work in aisles only slightly wider than the truck or the unit load carried and is fitted with a fork mechanism permitting Access on either side of the aisle without turning the main body of the truck.

NOTE 1: VNA trucks are normally guided within the aisles. Because of the accuracy required in placing pallets into the racking, these trucks usually pick the pallet loads up from a specially designed P & D station at the entrance to each aisle.

NOTE 2: A VNS truck is sometimes known as a Turret Truck.

3.32 Wide aisle racking: Pallet racking arranged to leave aisles of sufficient width to allow the forklift truck equipment to traverse the length of the aisle and to make 90° turns into the rack face for loading and off loading.

3.33 90° stacking: Placement or retrieval of a pallet where the forklift truck makes a 90° turn to face the rack during the placement or retrieval process.

NOTE: In making this turn, no part of the truck or load intrudes into the racking.

4. ELEMENTS

4.1 Palletised goods

Palletracking systems are designed to store palletised goods, containers or non-palletised goods. For each category, sufficient data must be furnished allowing the racking supplier designing the racking correctly.

It is understood by palletised good a palette composed whole unit plus load. Measured by its total weight.

These goods are different forms and are made of different materials:

- Wooden pallet
- Metallic or plastic pallet
- Container

The construction of any of these platforms must meet the following requirements:

- ISO and EN Standards.
- Be capable of supporting the deposited load.
- Fit with the model set out in the original design of the installation.



Wooden pallet



Metallic pallet



Container

The actual dimensions of the unit loads shall not adversely affect the clearances provided for safe operation.

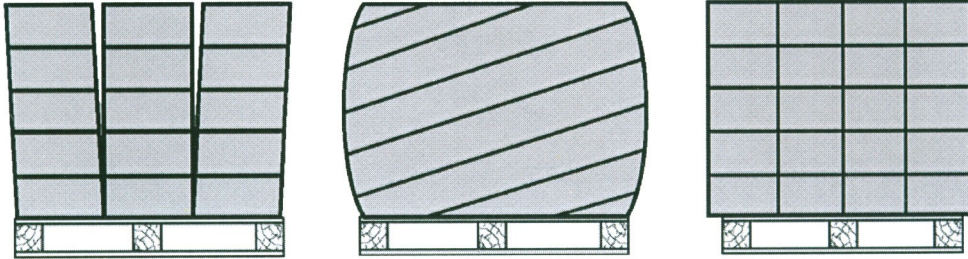

The pallets are defined in the following standards:

- EN 13382: Flat pallets for materials handling. Principal dimensions
- EN 13698-1: Pallet production specification - Part 1: Construction specification for 800 mm x 1200 mm flat wooden pallets
- EN 13698-2: Pallet production specification - Part 2: Construction specification for 1 000 mm x 1 200 mm flat wooden pallets

4.2 Floor of the building

The user is responsible for confirming the suitability of the intended floor or foundation for the loads being imposed upon it by the racking. The standard load tables take into account that the floor is solid concrete, min. 120mm thick and with a minimum strength of class C20/25 $f_{ck} = 20\text{N/mm}^2$ (EN 1992). If the floor is made from other materials, such as bituminous compounds, the racking supplier must be informed as special consideration is needed.

The floor flatness is given by the document EN 15620

4.3 Materials handling equipment

Mechanical, electromechanical equipment carried out by lifting are loading and unloading in storage systems, at the same time serving to transport the goods.

The most commonly used on shelves are:

- **Stacker:** Chauffeured aboard or at ground level.
- **Counterbalanced forklift:** three and four-wheeled
- **Reach truck:** counterbalanced with retractable mast
- **High-rise carts:** are divided into trilateral, bilateral and order pickers
- **High rack riser truck:** For automatic installations.



Stacker



Counterbalanced



Reach truck



Bilateral



Trilateral

The choice of one or another element will be conditioned by the following data warehouse:

- Sizes
- Corridors wide
- Max lifting height
- Max lifting load



High rack riser truck

4.4 Racking classes According to EN-15620,

- **Class 100:** Pallet racking arranged as for a very narrow aisle system but operated by a stacker crane. The aisles are wide enough only for the stacker crane or load width plus operational clearance as shown in figure. The stacker cranes are automatically controlled, do not have a fine positioning system at the unit load storage positions and are usually for storage systems less than 18m in height.
- **Class 200:** Crane operated installations where the stacker cranes are automatically controlled and have fine positioning system at the unit load storage positions. Also includes installations where the stacker crane is manually controlled.
- **Class 300:** Class very narrow aisle pallet racking is arranged with aisles of a width to cater only for the truck and the unit load width plus operational clearance. The unit loads are handled within the aisles without the need for the truck to turn bodily into the rack face. The trucks are usually guided into and along the aisle length by guide rails or a wire guidance system and have fixed or rising cabs.

Class 300A: Very narrow aisle installations class 300A are where the truck operator is raised and lowered with the unit load and has manual height adjustment to position the load man-up. Alternatively, the operator remains at ground level and has the use of an indirect visibility aid such as circuit television (CCTV) or an equivalent system to guide the operator.

Class 300B: Very narrow aisle installations Class 300B are those where the truck operator remains at ground level, mandown, and does not have the use of an indirect visibility aid.

- **Class 400:**

Class 400 Wide aisle: Wide aisle racking is arranged to leave aisles of sufficient width to allow fork lift truck equipment to traverse the length of the aisle and make 90° turns into the rack face for loading and off loading.

Class 400 Narrow aisle: Estantería de carga paletizada con pasillo reducido, que puede ser usada por carretillas más especializadas.

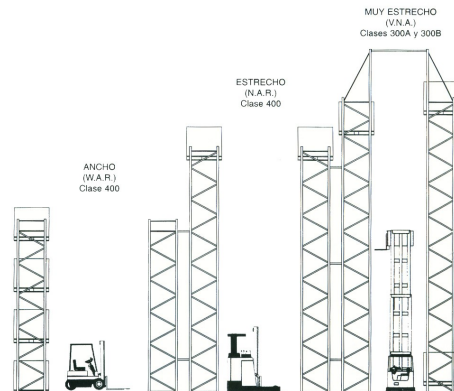

This use and maintenance manual will deal only with conventional pallet racking shelving.

5. DESCRIPTION OF THE OF SHELVES:

A system of conventional shelves for palletized load (APR) consists of alignments of racks placed vertically and connected to each other by pairs of beams which, in turn, are spaced in high enough to accommodate the intended load units.

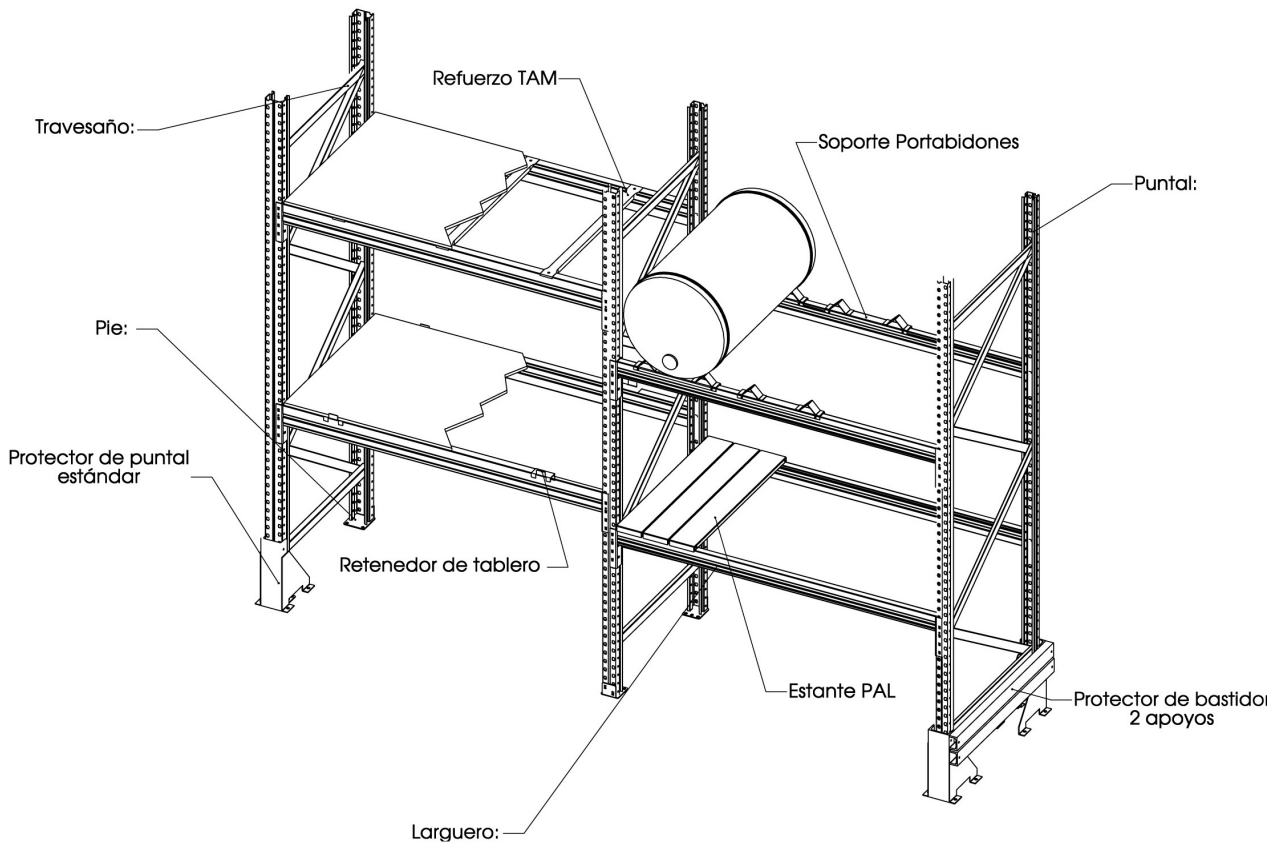

Designed implementation may not vary in any of its aspects (loading, geometry units...) without consulting with the KIMER Department technician.

It is expressly forbidden:

- Changing levels in height
- Modifying the number of levels (even preserving the load for casting)
- Modification of profiles
- Use of the installation with damage on main elements (frames, beams, safety pins, braced...)
- Use the installation when it detects a desaligned in one of the frames.

5.1 In relation to security, we must emphasize the following elements:

Protections:

According to standard UNE 15512, impacts on posts on the shelves with a proper formation of the forklift operator and through the adoption of security measures, which include the use of guards should be avoided.

As a minimum must be protections in posts on the corners located in the corridors of circulation or at junctions of corridors where the trucks change direction.

Protections must have a minimum height of 400mm and be able to absorb energy from at least 400Nm in any direction and at any height between 100 and 400 mm as it set forth in the attached on 15512.

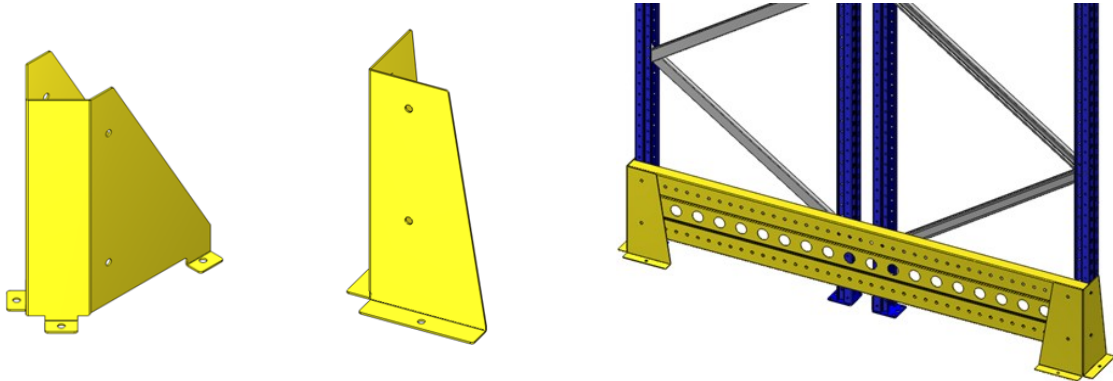

Pallet stop:

Profile located so that the pallet (never the load) is in contact constantly with the same. The function of this profile will be resist the efforts of positioning. At the same time shelving must be designed to absorb them.

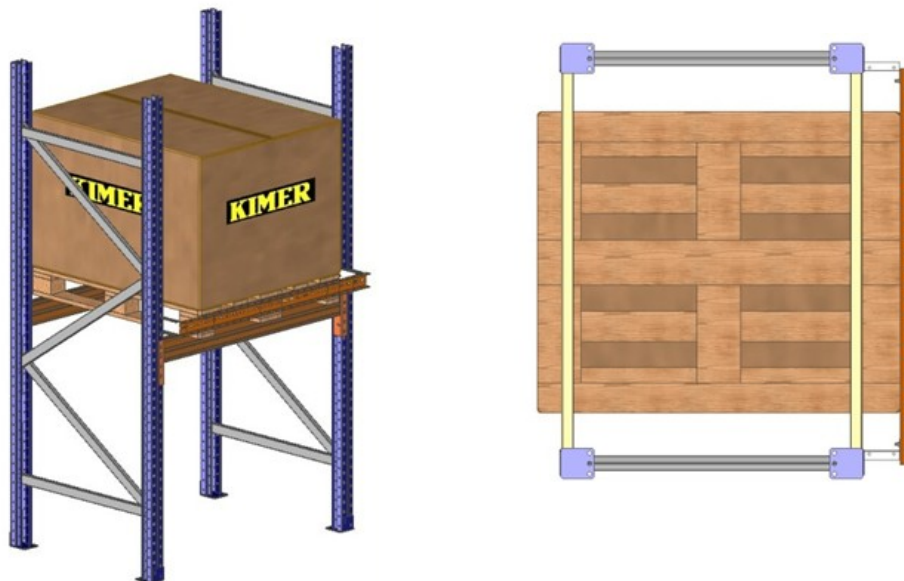

5.2 Manipulation of the charging unit

The elements that compose a conventional rack for pallet racking have been calculated to work in normal operating conditions, i.e. with static charges.

These conditions are not given if trolley with its load give rise to bumps, collisions, pushes, pulls, positioned sudden load... (see annex D) The deformation, sometimes, can be accompanied by damage to the connector and fall of the beam and its load.

- Positioning of the charging unit:

When there are more than two units of load per level it is recommended to place the ends first to have a reference of positioning of the pallets.

- The pallette has to be placed on the beams with sufficient surface área and with the supports well placed.

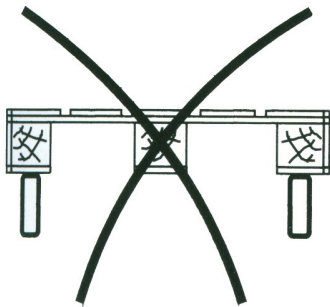

Fig. 7a - Dirección incorrecta de apoyo

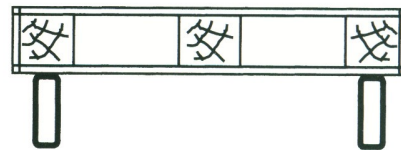
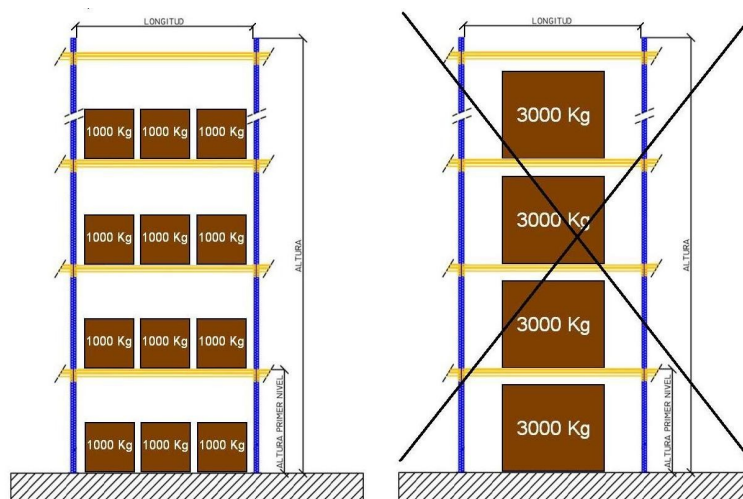
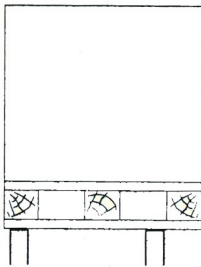

Fig. 7b - Dirección correcta de apoyo

- It must avoid a concentration of load in the middle of the beams, approximating the palletes, otherwise it will appear unacceptable deflections.



- Avoid the eccentricity of load relative to the position of the beams, otherwise, the more loaded beam will present more deflection than the right one.
- Avoid pallets with non distributed load. Its effect is an increase of the deflection.
- Avoid falls and sitting sudden load. It can lead to permanent deformation of the beam.
- Drag or horizontal push when positioning the load can cause turns and drags in beams.
- Sudden elevations can damage the top beam. However, safety pins prevent it to unlock.



Eccentricity on a beam

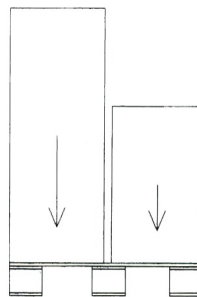

Palette with uneven load

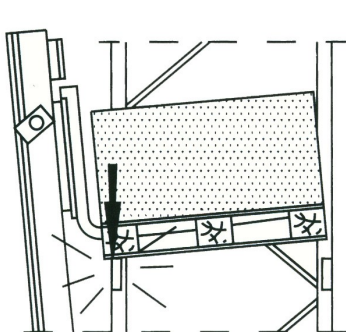

No horizontal descent of the load

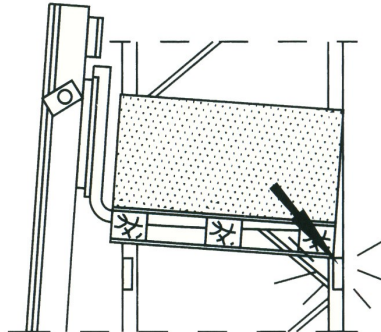

Drag or horizontal thrust

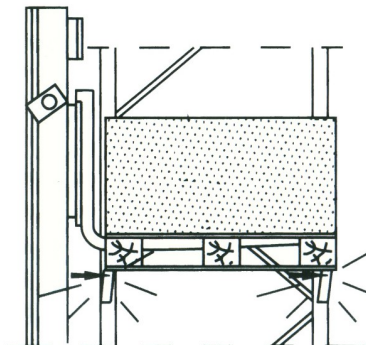
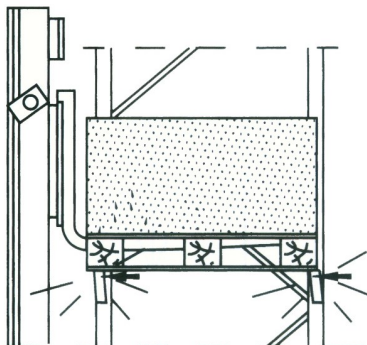

- Work clearances

Observe the minimum clearances established in the norm at 15620

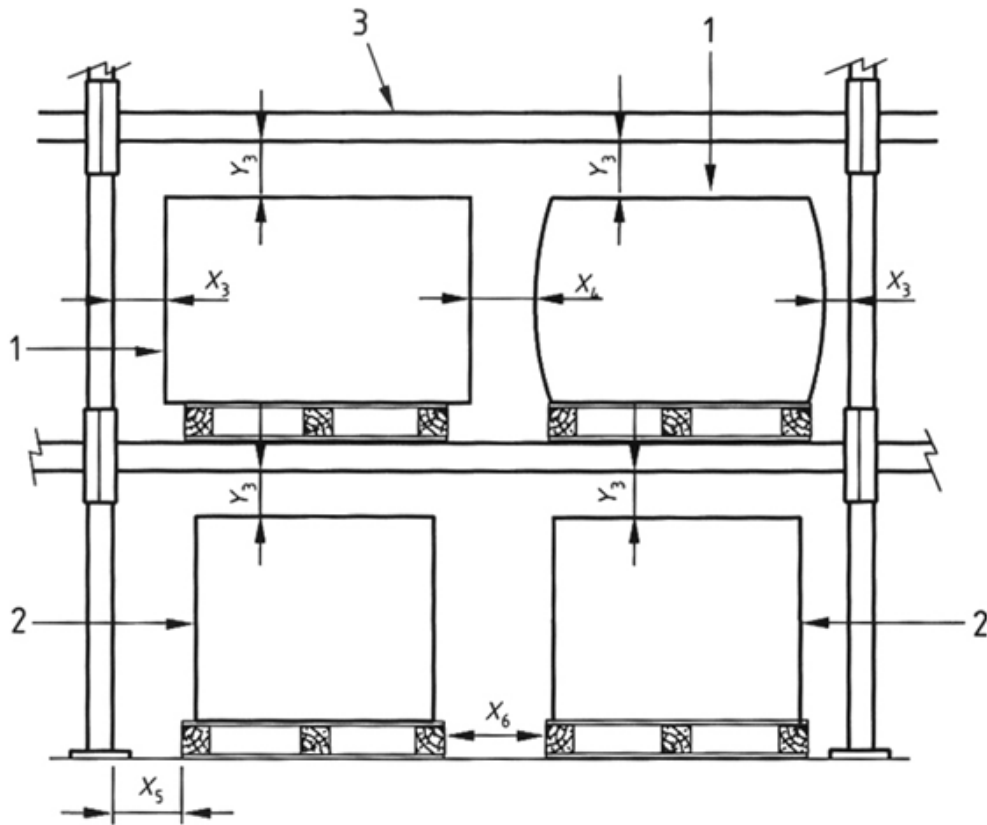

Height H from ground to beam level	Class 400		Class 300A		Class 300B	
	X	Y	X	Y	X	Y
$0 < H \leq 3.000$	75	75	75	75	75	75
$3.000 < H \leq 6.000$	75	100	75	75	75	100
$6.000 < H \leq 9.000$	75	125	75	75	75	125
$9.000 < H \leq 12.000$	100	150	75	75	100	150
$12.000 < H \leq 13.000$	100	150	75	75	100	175

- Horizontal gaps in depth without back stops.

Observe the minimum clearances established in the norm at 15620

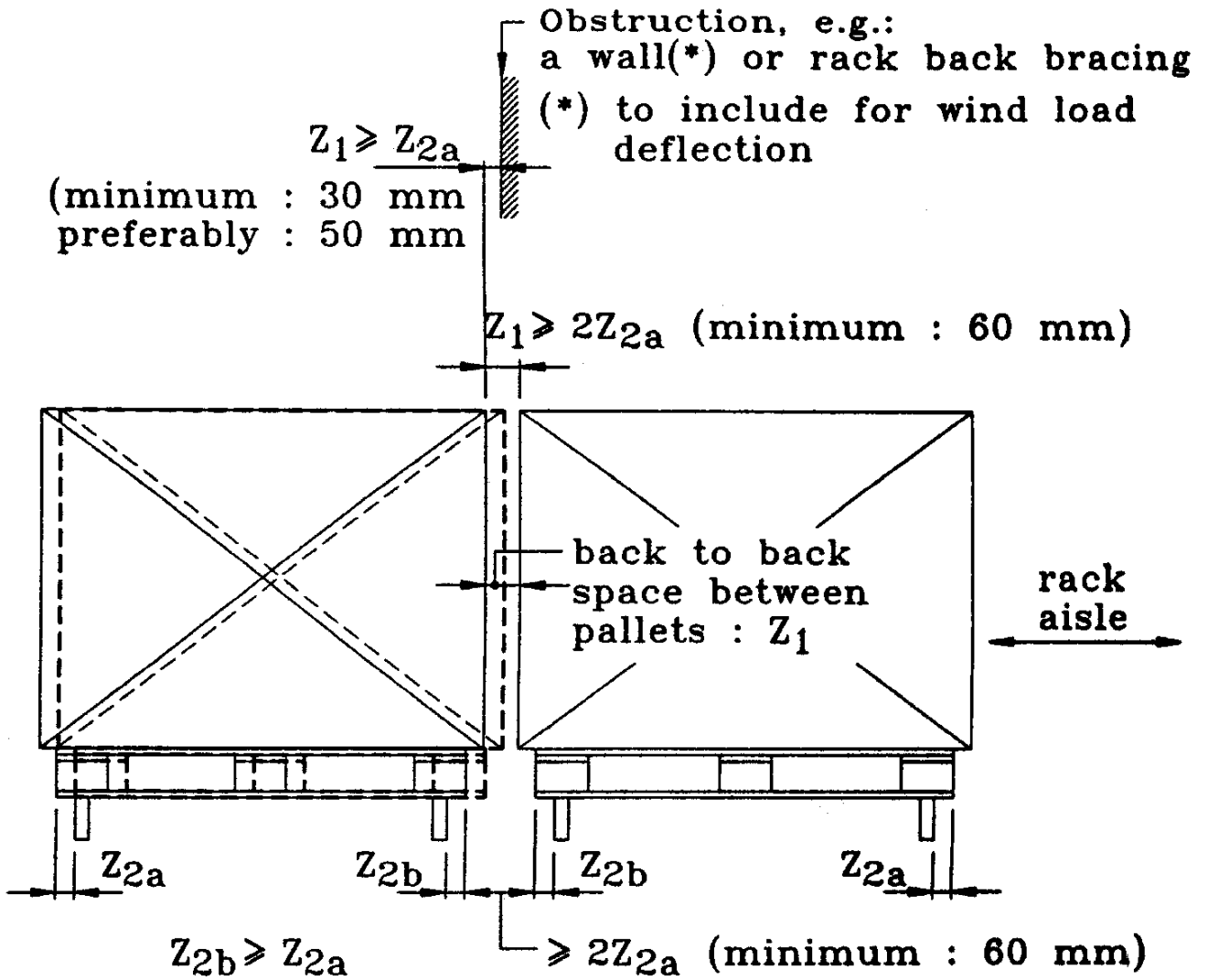

6. ASSEMBLY. ASPECTS TO TAKE INTO ACCOUNT:

To ensure safe use of the equipment for storage, we will attend to:

- A) Storage equipment must be mounted according to the specification, drawings and the detailed assembly instructions provided by the supplier.
- B) CHARACTERISTICS: The load capacity of the installation, which must be well known and respected.

These features should not be altered. Any change, modification or enlargement, requires study and express authorization from the supplier.

- C) LOAD: The maximum weight, the type of load and its stability must be known and respected:
- D) The ground should have the right strength, stiffness, leveling and flatness for use;
- E) Facilities must have warning load plates, given by the supplier, indicating therein sufficient information related to the type and characteristics of load, as well as safety warnings. This plate must always be in a place visible shelving or next to it.
- F) It is advisable to identify the corridors, in order to quickly locate a certain area of the installation with any damage in the elements.
- G) PRSES security officer must ensure that the stated maximum load level is not exceeded.
- H) End user shall be responsible for ensuring, during the routine use of the installation, the correct use according to the directions of the supplier and also the damage produced to the installation.
- I) The store where the shelves are placed will be suitable, it is recommended that the store has adequate lighting, appropriated ground and corridors are free of obstacles.

All the shelves must be fixed to the ground with suitable anchors according to the directions of the supplier and must be mounted according to the instructions of the supplier of the anchors

In the case of conventional shelves of double alignment must be mounted at least two spacers. The position of the spacer must be as close as possible from the knot of the frame to avoid local damage to the upright by bending. The number and the position must meet the following minimum requirements (see fig. 1):

- 1) Lower spacer next to the lower knot of the frame.
- 2) Highest spacer next to the higher knot of the frame .
- 3) If necessary, close the upright joint.
- 4) When the distance between the two spacers frame cited is exceeding 3 metres, it is recommended to place an additional spacer every 2-3 metres

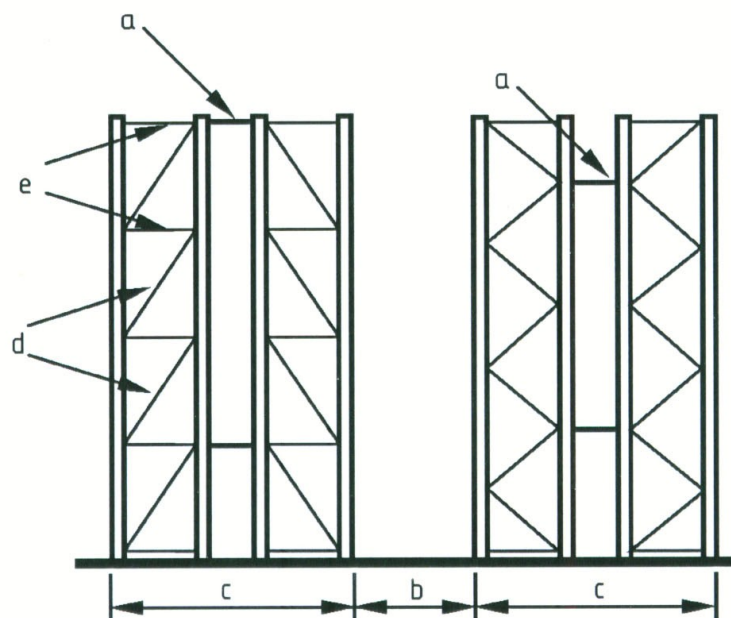

Leyenda

- a distanciador
- b pasillo
- c estantería de alineación doble
- d diagonales del bastidor
- e horizontales del bastidor

Figura 1 – Situación de los distanciadores

When provided vertical bracing elements, that elements may be provided to ensure the stability of the rack, must be anchored to the ground according to the instructions of the supplier. They must be mounted according to the manufacturer's instructions and must not be removed or reset.

Base plates must have its entire surface in contact with the ground of the building or other structural elements. The base plates must be level with plates of different thicknesses leveling. The gap between bases of a same frame must not exceed 1/500 of the width of the frame.

The space between beams, shelves, etc. It must not exceed the values provided by the supplier of the shelving, which correspond to their maximum loads permissible for the frames of the shelves as shown on the rating plates.

Beams must fit into place using safety pins.

Warning plates (see annex B) must be located in the right place.

CHANGES IN THE CONFIGURATION OF THE SHELVES:

Changes may occur in the permissible load capacity when the storage equipment is modified. In all cases of change call to the supplier or an appropriate expert and received instructions must be followed before making any changes.

- A) the shelves must be downloaded before making any changes.
- B) Additions or changes in storage by welding or screwed must not be allowed unless they are approved by the supplier of the equipment.
- C) The warning plates need to be updated according to the changes.

TOLERANCIAS DE MONTAJE

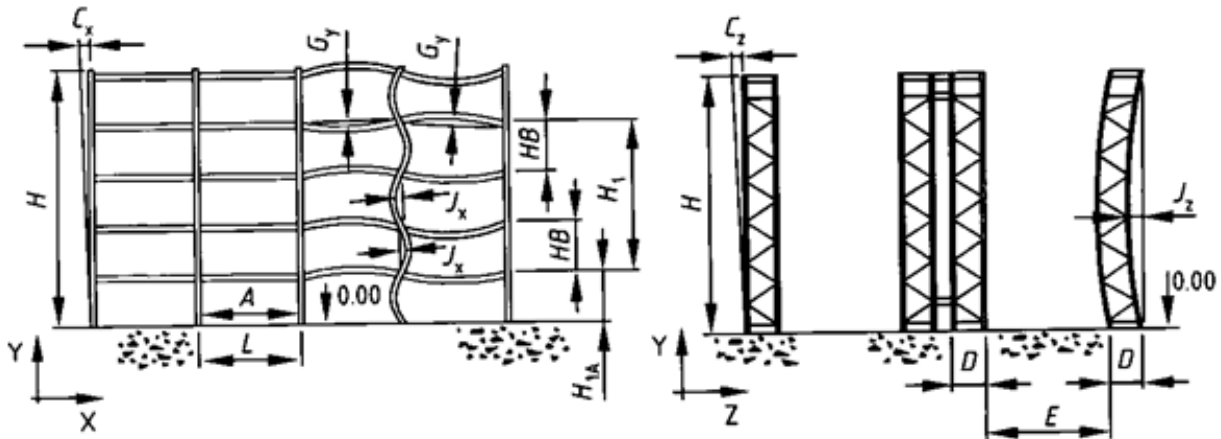

Table 2 — Tolerances measured horizontally

Horizontal tolerance limitations for X Z plane mm	
Measuring dimension code and description of tolerance	Installation tolerances for racking class 400
δA Variation from nominal dimension of the clear entry width between two uprights at any beam level	+ / - 3
δA_n Variation from nominal dimension of the total rack length, cumulative with the number of bays 'n' measured near floor level	+ / - 3n
δB_0 Variation from nominal of rack frontage with regard to the installation 'system Z datum line' concerned, measured near floor level	+ / - 10
BF Misalignment of opposing rack uprights across a frame	+ / - 20
C_x Out of plumb of each frame in the X direction	+ / - H/350
C_z Out of plumb of each frame in the Z direction	+ / - H/350
δD Variation from nominal dimension of the rack depth (single frame)	+ / - 6
δE Variation from nominal dimension of the aisle width near floor level	+ / - 15
δF Variation from nominal of the straightness of an aisle measured near floor level with regard to the 'aisle system X datum line'.	+ / - 15
G_z Straightness of the beam in the Z direction	+ / - A/400
	the larger tolerance of the following
J_x Upright straightness in the X direction between beams spaced HB apart.	+ / - 3 or + / - HB/400
J_z Initial curve of an upright frame in the Z direction	+ / - H/500
T_w Beam twist at mid span	1° per m

Table 3 — Tolerances measured vertically

Vertical tolerance limitations for Y direction mm	
Measuring dimension code and description of tolerance	Installation tolerances, for racking class 400
	the larger tolerance value of the following
G_y Straightness of the beam in the Y direction	+ / - 3 or + / - A/500
δH_{1A} Variation of the top of the bottom beam level above the base plate	+ / - 10
δH_1 Variation of the top of any beam level H_1 above the bottom beam level	+ / - 5 or + / - $H_1/500$
H_y Variation of support levels between the front and rear beams in a compartment	+ / - 10

NOTE A measurement survey may be used to measure the installation tolerances and clearances before the racking is loaded. The tolerances stated in this European Standard may not be applicable after the racking has been loaded.

Measurement surveys may be completed when required by individual contracts (see Annex C).



7. CONSIDERATIONS FOR THE USE OF SHELVING

To establish the correct use, we will attend the five fundamental aspects of the installation.

1. **THE CHARACTERISTICS OF THE INSTALLATION:** The load capacity of the installation, which should be known and respected.
2. **LOADING UNITS:** Maximum weight, the type of load and its stability, the dimensions of the load and type of palette must be well known and respected.
3. **THE MANIPULATION OF THE LOADING UNIT:** Recommendations for handling the charging unit and the maintenance of forklifts must be known and followed.
4. **THE TRAINING OF THE STAFF:** staff working in the facility must know the materials you are using and follow the established guidelines.
5. **STORE:** The building that hosts the installation shall have the minimum requirements for a proper use of the shelves.

8. MAINTENANCE AND INSPECTIONS (according UNE EN 15635)

PERIODIC INSPECTIONS;

The significance that may have impacts and damages not served on time is recommended that a internally periodic inspection exist at;

- Damage to frames and their components; uprights, base plates and diagonals
- Failure of verticality in uprights
- Effectiveness of the beam-upright connection
- Broken welds or material next to these welded components
- Tighten screw connections
- The ground building conditions
- Correct mounting of the shelf according to the assembly instructions

Other items to check are::

- updated security plates
- There is no overload at load positions
- Loads do not overhand from the outer perimeter of the alveolus
- The dimensions of loading units are satisfactory

Guideline recommended;

- weekly visual inspection of the lower levels (1º y 2º)
- More detailed monthly inspection of the other levels
- Annual inspection by competent and experienced staff

Immediate notification: as soon as anyone detect security problems or damage should notify immediately the PRSES

Visual inspections: La PRSES must ensure that inspections are carried out weekly or other regulated intervals. You must keep and maintain a record of the inspections.

Inspections by an expert: A competent person should be technically carry out inspections at intervals of not more than 12 months. A report must submit written to the PRSES with observations and proposals for action to follow.

CRITERIA FOR THE EVALUATION OF DAMAGE; **EVALUATION OF FRAMES**

These rules apply only to damage causing a general bent in an element (see fig. 14). They do not apply to damages punctual located such as dent, folded, tears and cracks. The folded in less than a meter can be judged is apportioned to the limits of one meter; for example, recommended limits are applied over half a meter in length. Elements with tears and cracks should reponse always. The measurement of damages must be performed as follows:

- A) Place a rule of 1. 0's long contact with a surface flat on the concave side of the damaged item, in such a way that damaged surface is as centered as possible, the length of the rule.
- B) For an upright folded in the direction of the beams, the maximum separation between the upright and rule must not exceed 5.0 mm
- C) For an upright folded in the direction of the frame, the maximum separation between the upright and rule must not exceed 3.0 mm;
- D) For an upright that has been damaged in such a way that it is bent in both directions, longitudinal and lateral deformation from left to right and front to the back, should be assessed and considered separately and 5.0 mm and 3.0 mm indicated; limits should be respected
- E) For elements of the truss bent in any plane, the separation between the rule and the diagonal element must not exceed the 10.0mm on a stretch of pattern of length 1.0 or pro rata for shorter frames where cannot use section pattern of length 1.0 m.

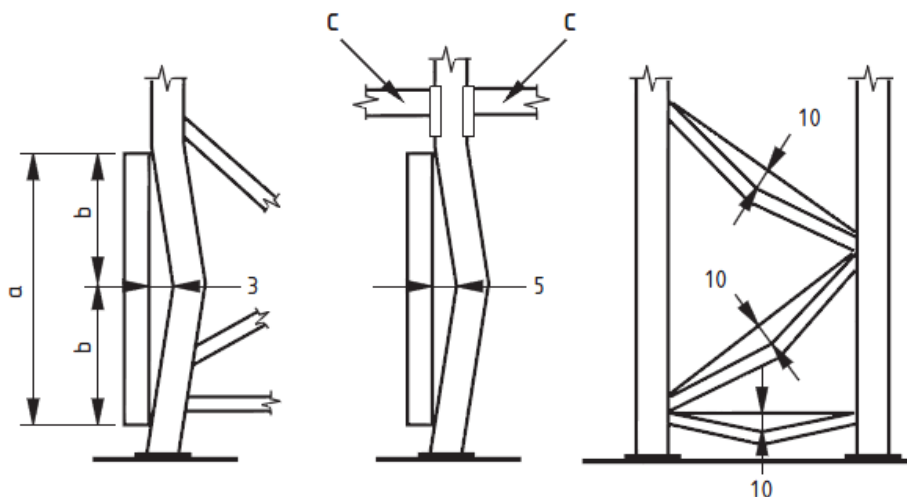

Key

- a gauge length 1000
- b half the gauge length
- c pallet racking beam

Figure 14 — Elevations showing method of damage measurement of typical adjustable pallet racking upright and bracing sections

CRITERIA FOR THE EVALUATION OF DAMAGE; **EVALUATION OF BEAMS**

To evaluate the damage on beams:

- Residual vertical deformation (which remains after the unloading the beams), caused by accidental overload. It should not exceed 20% of the normal deformation under permissible total load ($L/200$ under load).
- Residual lateral deformation. It must not exceed 50% of the deflection under full load admissible($L/200$).
- Connectors that have obvious visible deformations must download and seek advice from an expert.

The localized damage in the form of dents, cracks, etc. must be assessed in each case in doubt, download the level and change the damaged beam.

Safety pins:

It is imperative that all beams have placed their two safety pins. This will prevent from that accidentally a stringer no longer catches his accommodation.

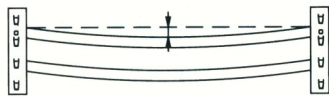

Fig. 13 - Deformación vertical de un larguero

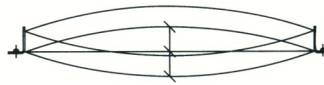

Fig. 14 - Deformación horizontal de un larguero

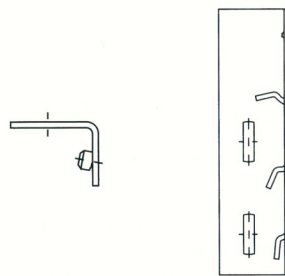

Fig. 15 - Conector. Deformación y rotura de uñas

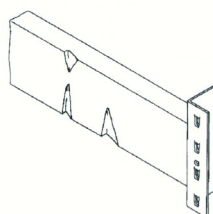

Fig. 16 - Abollado de largueros

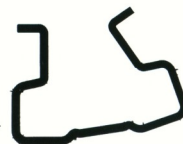

Fig. 18 - Deformación del perfil del puntal

ANOMALIES AND FAILURES. MOST COMMON RISKS:

It is then exposed in a box the most common risks, effects on the shelves and the advice to avoid them.

In beams:

ANOMALIES AND FAILURES	CONSEQUENCES	HOW TO AVOID THEM
Overload	Excessive deflection. Permanent vertical deformation and subsequent fall.	Control of the weight of loading units.
Non-uniform distribution of loads	Excessive deflection. Permanent vertical deformation and subsequent fall.	Follow the recommended guideline AEFEM 211-1998
Positioned sudden load	Excessive deflection. Risk of fall of the beam.	Control positioning of the load.
Absence of locking pin	Risk of fall of the beam.	Verify the presence of safety pins.
Hits with machinery or load	Lateral deformations. Risk of fall of the beam.	Follow the recommended guideline AEFEM 211-1998
Oxidation and ruined paint	Reduction of the useful life. Breakage and subsequent fall of the beam	Use maintenance programs to prevent corrosions

In frames:

ANOMALIES AND FAILURES	CONSEQUENCES	HOW TO AVOID THEM
Overload	Excessive uprights deflection Buckling and torsion accused Frame collapse	Control of the maximum weight per bay.
Hits with machinery or load	Dents (fig.19) Permanent deformation in uprights and diagonals(fig.17) Permanent deformation in the profile section(fig. 18) Break or tear in the profile(fig. 20) loss of verticality	Follow the recommended guideline AEFEM 211-1998

When assessing the damage, we will follow the following criteria;

GREEN LEVEL: Only required surveillance, it corresponds to the cases with damage where not exceed the limits listed above.

AMBER RISK: Cases in which the limits of damages listed above are exceeded by a factor less than two. They are dangerous damage and it must act through the replacement of the damaged items.

RED RISK: Serious injury requiring immediate action. Situations where the limits are exceeded by a factor greater than or equal to two. It's a situation where the level of damage is critical.

DAMAGE TO THE PAINT

Serious damage: progressive Corrosion of the shelves

Review shall include the damage in the paint. Chafing or landslides which leave exposed steel must be retouched with paint.

In aggressive environments, this work is unnoticed that decreases in thickness and/or section don't give deep corrosion.

REUSED SHELVES

Serious damage:

Assemblies or elements of shelves from an already used installation, do not offer sufficient guarantee returning to be transferred and installed on another site, unless a thorough examination, carry out piece by piece, from the accumulated damage. The original configuration of the installation should also be maintained.

The manufacturer does not guarantee the behavior of the reused shelves.

CRITERIA FOR THE EVALUATION OF DAMAGE; **REVIEW OF SHELVING**

Flow chart of procedures for Inspeccion-evaluacion - action:

Reuse and recycling

This point refers both to complete installations and isolated components.

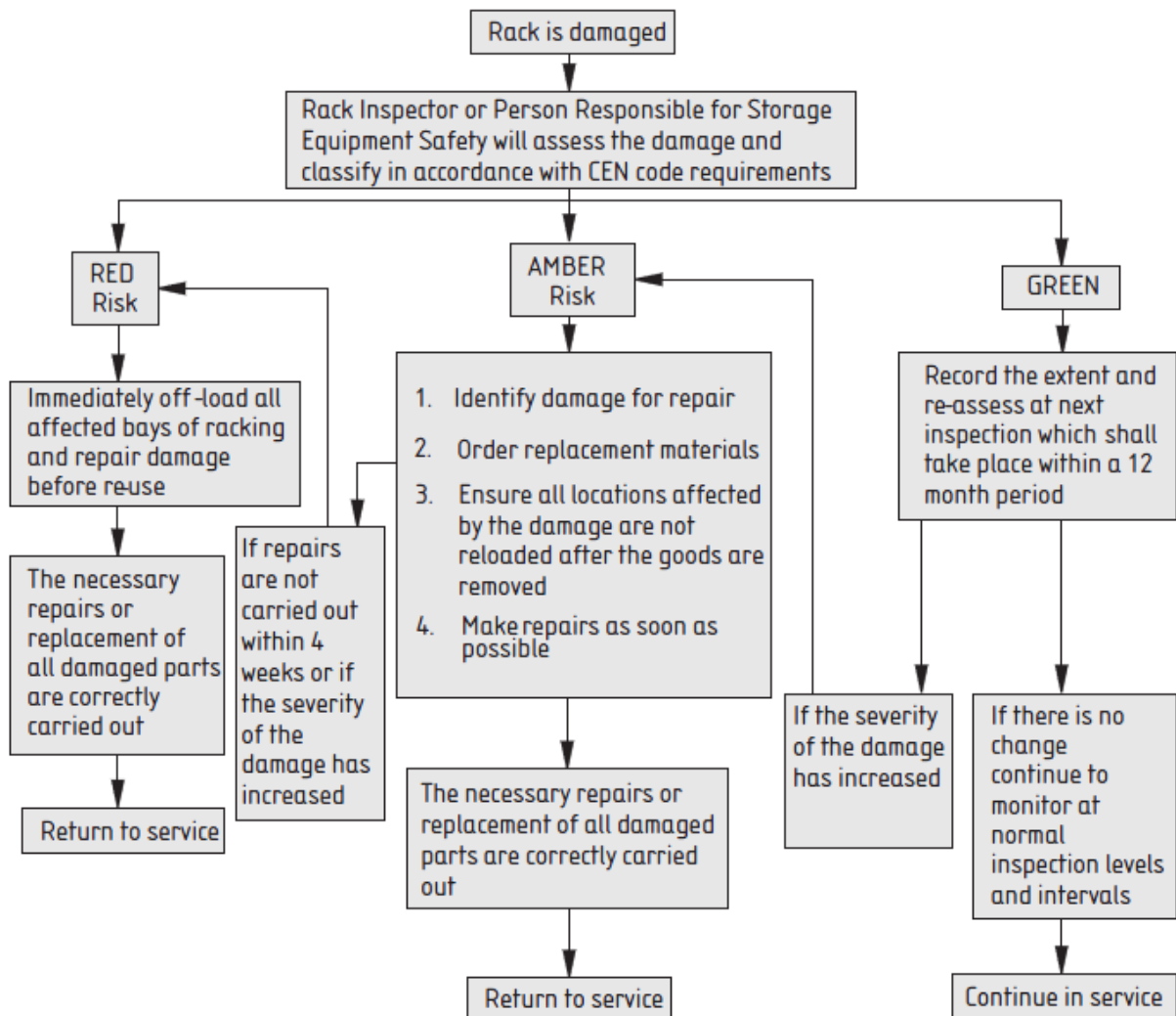

The transfer of a complete installation or some isolated item from a location to another involves changes in their behavior that affect the load capacity of the installation, and which cannot be predicted without a proper preliminary study.

KIMER is not responsible for materials and/or reused without a previous study facilities. Any change or extension must be approved by KIMER.

At the end of the service life of a component or complete installation, it is advisable to remove the material to a suitable waste management.

REVIEW OF THE FLOOR AND CORRIDORS

The ground, as a main element of the installation, need to be verified in the following aspects:

Planimetry: Must respect the planimetry for which the warehouse is designed. If not, might be affected the collapse of the system of storage with the consequent danger of fall of the installation. Possible irregularities of the floor can be corrected with the use of leveling plates arranged beneath the feet of the storage system.

Resistance: Slab must have adequate strength to withstand the pressure that transmit the foot of frames. There should be no areas where appreciate any collapse, since this might cause the collapse of the installation. If sinking or movement of the slab, the verticality of the installation may be damaged.

Cleaning: Both the pedestrian corridors and the work corridors, as those of circulation are kept clean and free of obstacles, in order to achieve safe operating conditions.

You should avoid:

- Obstacles in the middle of the corridors to minimize the risk of impact on the storage system.
- Stains of oil, liquids, or any other cause that might produce landslides of the elements of maintenance or cause people to slide.

REVIEW OF THE CHARGING UNIT

Damage or defects which make a pallet unacceptable for use in pallet racking are give in the next figure:

NOTE: See EN ISO 18613

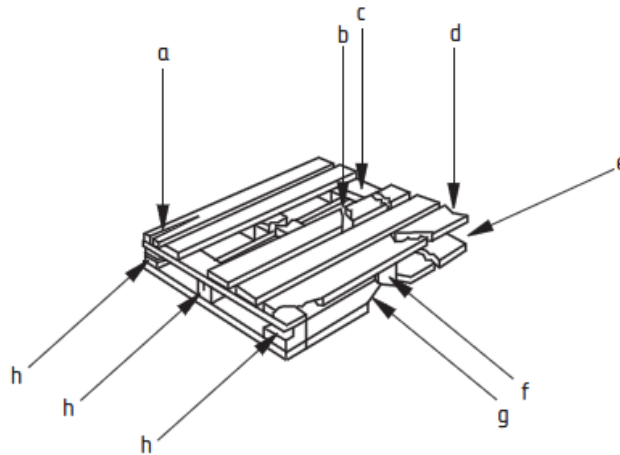

Key

- a splits on boards of more than half of the width or the length of the board
- b broken board
- c missing board
- d missing wood on a board of more than a third of the width of the board
- e missing block
- f block turned more than 30°
- g missing wood on a board between two blocks of more than a quarter of the width of the board or if nails are visible,
- h missing wood or splits on a block of more than half of the width or height of the block

In addition, the palette can no longer be reused if:

- A) Nail heads or nail points are protruding from the boards;
- B) Inadequate components have been used (boards or blocks too thin, too narrow, too short);
- C) General condition is so por that load-bearing capacity cannot be ensured (rotten boards or several splits in boards or blocks) or the merchandise is at risk of being dirtied.

A skid pallet cannot be re-used if:

- i) Boards are missing or broken
- ii) wood is missing on lead boards to such an extent that on one board two or more nail shanks are visible or, on more than two boards, one or more nail shanks are visible.
- iii) Blocks are missing, bronken or Split to such an extent that more than on nail shank is visible.
- iv) essential markings are missing or illegible

ANNEX A. SPECIFIERS' AND USERS' RESPONSIBILITIES (Informative)

User of storage equipment have specific responsibilities for ensuring safe conditions of operations for their workers and the stored goods.

Specifiers and users of storage equipment should have responsibility for:

- A) Specification of the maximum weight and gross dimensions of the goods or unit loads to be stored and any variation in conformity which may occur;
- B) Specification of the racking foundation properties to ensure sufficient strength and stiffness to carry the loads and for specifying any surface layer, floor fixing limitations, surface flatness, etc...
- C) Specification of specific loads applied by the material handling equipment, such as stacker cranes, fork lift trucks, use of pallet stops, pushing and sliding the goods when in contact with storage equipment, etc...
- D) Specification of the site location for the calculation of wind, snow and seismic load, if applicable.
- E) Allowing for the minimum clearances, so that the chance of collision between loads or between load and storage equipment will be minimized. Relevant data should be provided by the supplier or the mechanical handling equipment
- F) Specifying the environment, e.g. dry, unpolluted internal or external exposed to wind and weather, in order to determine the quality and durability of the paint or other steel surface treatment for its protection
- G) Specifying surface levelness and flatness for the floor
- H) Use of the storage system in accordance with the contract specification supplied
- I) Ensuring that the detailed assembly and installation instructions provided by the storage equipment supplier are correctly implemented when the installation of the equipment is undertaken by the user or a contractor appointed by the user (installation of equipment by the supplier or manufacturer is the preferred option)
- J) Specifying or providing upright protection where required
- K) Environment including the floor slab is dry, non chemically aggressive and internal
- L) Regular inspections of the racking or shelving structure during its life to ensure that any damage incurred is repaired or damaged component replaced with identical new parts from the same manufacturer
- M) Provision of personnel, trained in the use of materials-handling equipment and the storage capabilities of the racking or shelving, to safely operate the storage facility
- N) Providing appropriate heating and lighting over the storage area

ANEX B. SUPPLIERS' RESPONSIBILITIES (Informative)

The suppliers' responsibilities may be summarised as follows as a non-exclusive checklist for the specifier to enable the user to confirm that the system is appropriate to their requirement and safe to operate

The supplier should:

- A) Specify the technical limitations of the system in terms of its safe operating conditions and carrying capacity considering the specifiers requirements based upon EN 15620, prEN 15629 and EN 15635. This may be done by the provision of a drawing or drawings detailing dimensions and the position of the racking with clearances and operating aisle widths shown. This will identify any specific features of the system such as imposed loads or non standard operating conditions, which have been incorporated into the design, Any load accessories provided should be identified.
- B) Identify what rack protection equipment is provided as a standard with the system and what additional rack protection equipment is available as a post-installation addition.
- C) Identify and truck operating types or criteria of use that have been incorporated into the lay out of the racking or the design of the structure
- D) Carry out the structural design based upon EN 15512 or when not available by the European industry's codes of practice
- E) Provide, if required, an installation service by a team of trained and experienced installers working under qualified supervision. This should include a formal handover certificate signed by a competent person presented to the client confirming that the work has been completed to the specified standard
- F) Make available for the purchase of replacement components to allow effective repair and maintenance of the racking
- G) Provide ongoing technical advise to the user of the racking, particularly relating to the effects of change of use, change of load, or reconfiguration of the rack geometry to suit new requirements
- H) Provide advice to the user of the racking on the need for regular scheduled inspection routines and a formal maintenance programme to deal with any accidental damage that may occur (see advice in EN 15635)
- I) Supply load notices in approved safety colours providing information on the limitations of the system (see advise in EN 15635).

ANEXO C. LAY OUT OF LOAD WARNING NOTICE



Conduct regular inspections to check for:
 - Correct application and use;
 - Loads within allowable safe limits;
 - Accidental damages or dislodgement of structural components



REPORT ALL DAMAGES TO THE 'PERSON RESPONSIBLE FOR STORAGE EQUIPMENT SAFETY'



Do not alter the structure without either:
 - checking effects against manufacturers 'technical data', or;
 - obtaining approval from supplier



DO NOT CLIMB RACKING



Refer to 'EN15635: Steel static storage systems - Application and maintenance of storage equipment'



If in doubt **ALWAYS** contact supplier

Date of delivery	Project reference

PALLET UNIT		
	Type	Maximal load (Kg)
	Units per level	
Maximal dimensions (mm) (DxWxH)		

SHELVING			
	Levels h (mm)		
	1º	2º	3º
	5º	6º	7º
	8º		
BEAM DATA (the load must be uniformly distributed)			
Beam	Levels	Length (mm)	Weight per level (Kg)
FRAME DATA			
Type of upright	Height (mm)	Depth (mm)	Total weight of module (Kg)

Rack supplied by:

ENVIRONMENTAL PROTECTION

In Kimer are really aware of **our social responsibility as a company**. This is the reason why we invest every year in reducing our ecological footprint in all our manufacturing processes. Some of our achieved points are:

- We don't use any toxic for environment product in the painting process.
- Inverse osmosis is done to all water used in our factory.
- Pyro lytic ovens are used to process the hooks and remove paint remains, before recycle them.

We have ISO 14001

SOCIAL ACTION

Kimer believes in social responsibility of enterprises and in that the change is posible. Thus, in collaboration with Vicente Ferrer's foundation, Kimer has funded the projects below:

Housing buildings construction.

Construction of a school.

Construction of a milk factory.

All together will make posible families in Anantapur have access to a decent live conditions.

For more information:
www.fundacionviventeferrer.org



RAZONES PARA ELEGIR KIMER

1- DEPARTAMENTO DE CALIDAD:

Asegura un control sobre la calidad de los aceros empleados así como del producto final.



2- DEPARTAMENTO DE I + D PROPIO:

un equipo de profesionales y los programas de cálculo y fabricación más avanzados aseguran el diseño más eficiente.



3- DEPARTAMENTO DE INGENIERIA:

Un equipo de ingeniería unido a los programas de cálculo de estructuras más avanzados aseguran una calidad sobresaliente para cada instalación.

Nuestros productos se someten a pruebas de carga en el departamento de estructuras de la universidad politécnica de valencia.



4- MEJOR TECNOLOGIA EN LA FABRICACION:

Kimer dispone de maquinaria cnc de última generación, soldadura robotizada y pintura epoxi que aseguran una calidad precisa así como un acabado impecable.

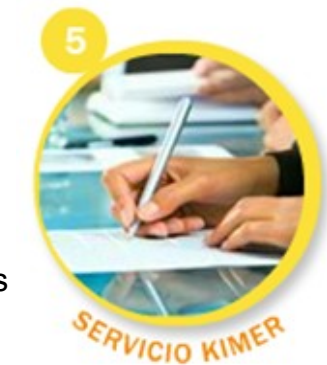

5- SERVICIO KIMER:

Nuestros plazos de entrega son los más rápidos del mercado.

Kimer lleva un estricto control sobre el montaje de las estanterías para asegurar la calidad final de cada instalación

6- ISO 9001 e ISO 14001:

Disponemos de la certificación de calidad ISO 9001 e ISO 14001.



CARGA LIGERA



Taquillas metálicas



Estanterías Clasificadoras



Estanterías de Comercio



Estanterías Easy rack Evolución



Archivo Móvil

CARGA MEDIA



Picking

GRANDES CARGAS



Paletización convencional



Paletización compacta



Kimlever



Entreplantas



Autoportantes



Naves Modulares

KIMER
creamos espacio

