

1	1	ZKLADOOS	DOOS MET BEVESTIGINGSMIDDELEN KLAPHEK 1100
4	2	ZBOOKLA	LEUNINGSTAANDER 50/50*1100 TBV KLAPHEK
3	2	ZKLAF250	KLAPHEK FRAME OPEN L/R H=1100 B=2500
Pos	Aantal	Struct. nr.	Omschrijving
		Klant:	
		Referentie klant:	
Ons ordernr.:		Print datum: 18-4-2025	
Datum: 18-10-2023		Getekend: JHU	
Produceren: Volgens EN1090-2 en exc.kl. 2		Bouwjaar:	
Conserveren: Poeder coating, indien THVZ: EN1461 met EN10346		Tekening nr.: ZKLA2500	
Benaming: KLAPHEK B=2500 H=1100 (2X B=1250) OPEN		Amerikaanse projectie: 	
		Rev. Ee nh. Formaat MM A4	

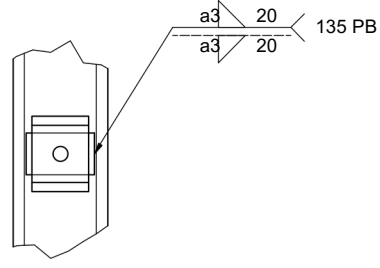

A

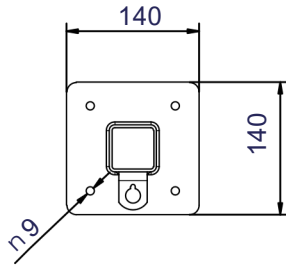
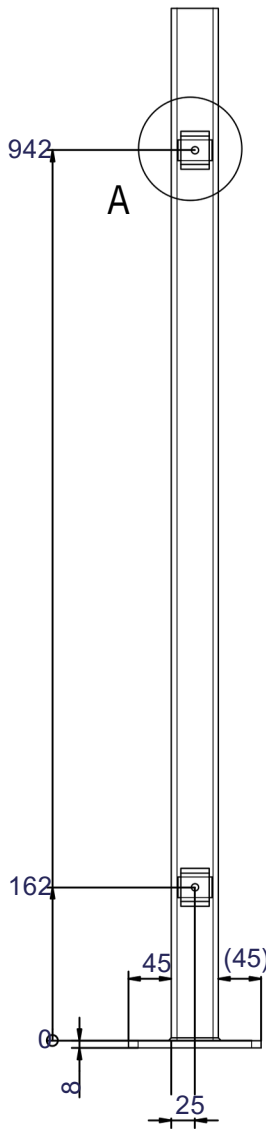
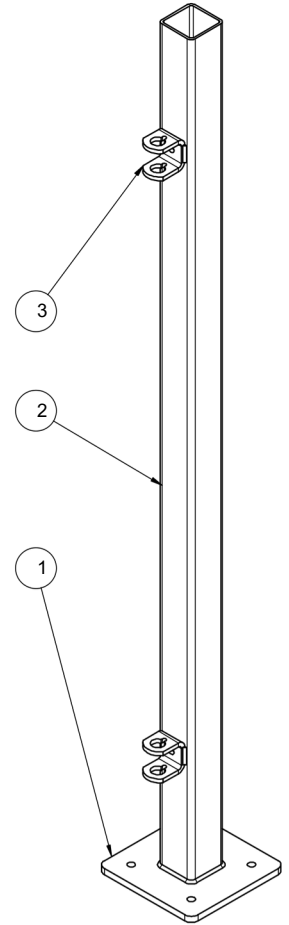

A

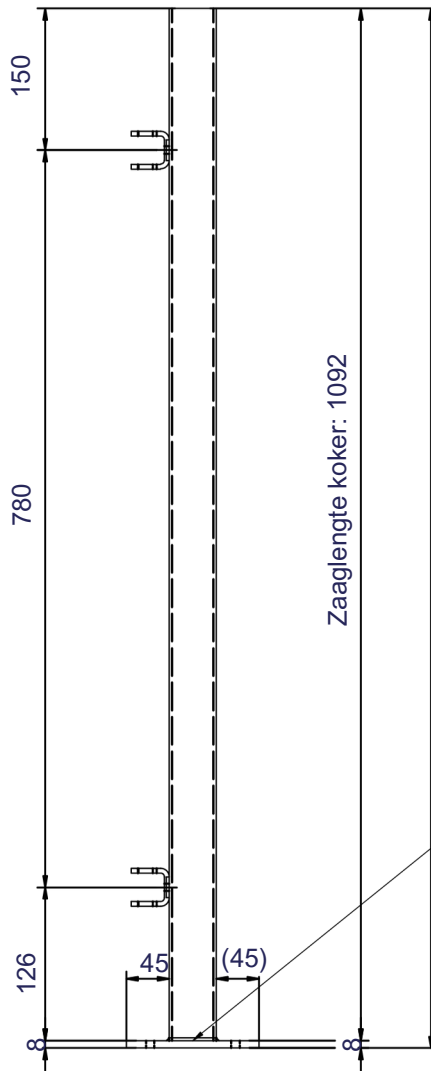

Zaaglengte koker: 1092

1100

1

2

3

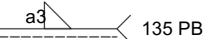

1	1	ZV14144	VOETPLAAT 140X140X8 4X Ø9
2	1	BU5050503-01 tbv ZBOKLA	KOKER 50X50X3 S235JRH ZAAGLENGTE KOKER =1092
3	2	ISB997160-BEUGEL	POORTSCHARNIER BEUGEL
Pos	Aantal	Struct. nr.	Omschrijving
		Klant:	Amerikaanse projectie:
		Referentie klant:	Print datum: 18-4-2025
		Ons ordernr.:	Getekend: JHU
		Datum: 15-9-2021	
		Produceren: Volgens EN1090-2 en exc.kl. 2	Bouwjaar:
		Conservieren: Poeder coating, indien THVZ: EN1461 met EN10346	Tekening nr.:
Benaming: LEUNINGSTAANDER 50/50*1100 TBV Klaphek			ZB00KLA
		Rev.	Eenh. MM Formaat A4

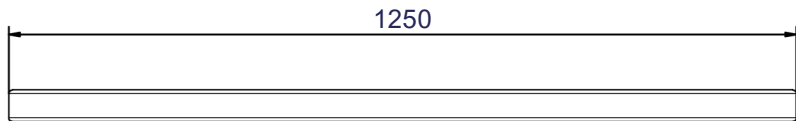

1250

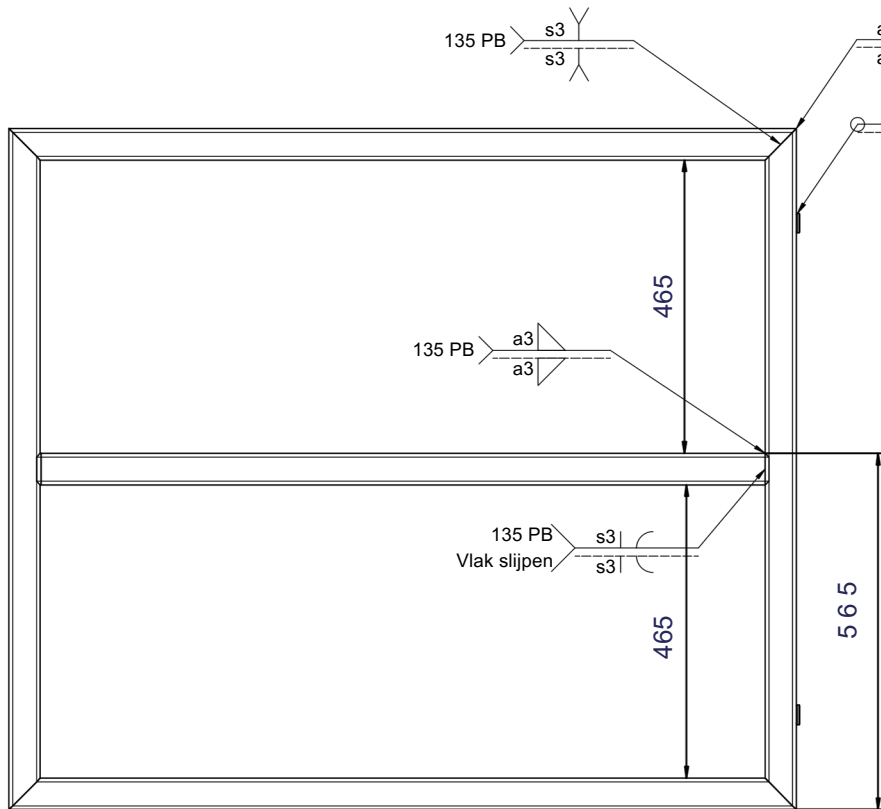

135 PB

s3
s3

a2

a3

135 PB

Buitenhoek vlak lassen

a3

135 PB

135 PB

a3

a3

465

135 PB

s3

s3

Vlak slijpen

465

565

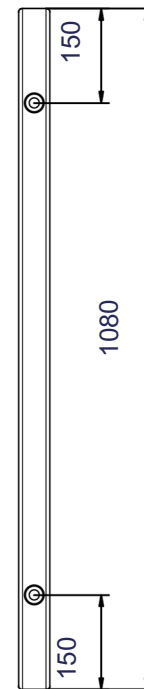

150

1080

150

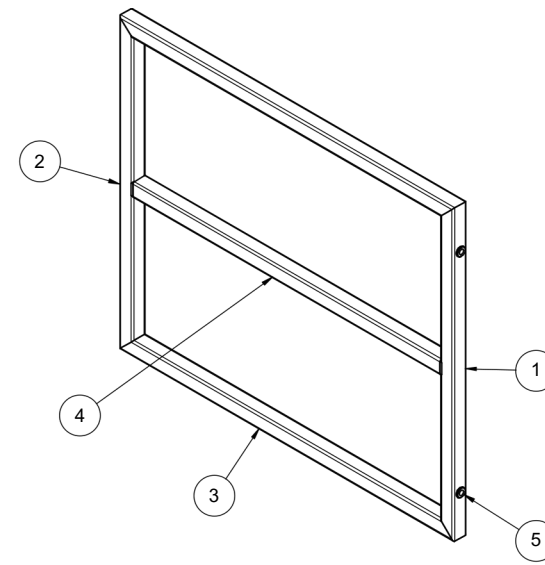

1	1	BU5050503-01 tbv ZKLF1100H	KOKER 50X50X3 S235JRH
2	1	BU5050503-02 tbv ZKLF1100H	KOKER 50X50X3 S235JRH
3	2	BU5050503-03 tbv ZKLAF250	KOKER 50X50X3 S235JRH
4	1	BU5050503-04 tbv ZKLAF250	KOKER 50X50X3 S235JRH
5	2	ISB997160-INLASMOER	POORTSCHARNIER INLASMOER M16
Pos	Aantal	Struct. nr.	Omschrijving



Multi Profiel_{bv}

Klant: _____

Referentie klant: _____

Ons ordernr.: _____

Datum: 15-9-2021

Producers: Volgens EN1090-2 en exc.kl. 2

Conserveren: Poeder coating, indien THVZ: EN1461 met EN10346

Benaming: Klaphek frame open L/R H=1100 B=2500

Getekend: JHU

Print datum: 18-4-2025

Bouwjaar: _____

Tekening nr.: ZKLAF250

Amerikaanse projectie:



Rev. _____

Ee nh. **MM**

Formaat **A4**